

WEATHERPROOF ENVIRONMENTAL HOUSING SERIES

INSTRUCTION MANUAL

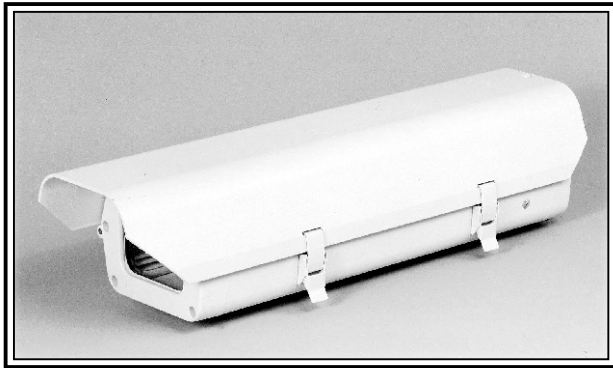

Please read this manual thoroughly before use, and keep it handy for future reference.

THIS PAGE INTENTIONALLY LEFT BLANK.

CAUTION

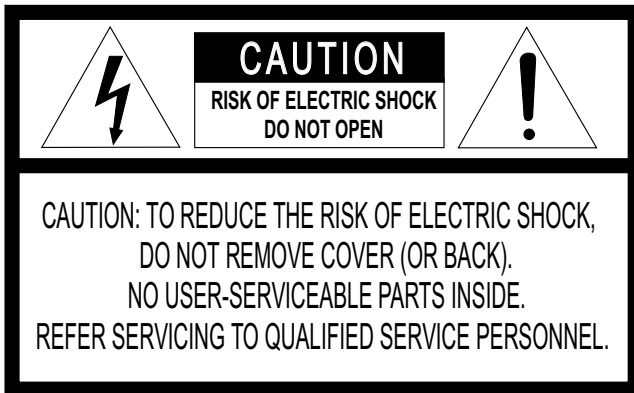

EXPLANATION OF GRAPHICAL SYMBOLS



The lightning flash with arrowhead symbol, within an equilateral triangle, is intended to alert the user to the presence of uninsulated "dangerous voltage" within the product's enclosure that may be of sufficient magnitude to constitute a risk of



The exclamation point within an equilateral triangle is intended to alert the user to the presence of important operating and maintenance (servicing) instruction in the literature accompanying the product.

- ※ **FIELD INSTALLATION** - This installation should be made by a qualified service person and should conform to all local codes.

1. DESCRIPTIONS

These weatherproof environmental enclosure series are constructed from die cast and extruded aluminum. They are available for 9.5-inch(24.13cm), 12.5-inch(31.75cm) and 15.7-inch(39.87cm) lengths.

These enclosures are for use with 1/2-inch and 1/3-inch format cameras and fixed focal length lenses or motorized zoom lenses. (With or without auto-iris operation)

These enclosures have an optional field-installed heater and sunshield.

These enclosures can also be factory ordered with a 24V, 120V or 230V heater and blower kit.

The side hinged lid provides easy access to the removable camera sled.

Two adjustable (PG10) glands on the rear of the enclosure allow for easy installation of the power and video cables.

2. PRODUCT FEATURES

- . For 1/2-inch or 1/3-inch format CCD cameras
- . All aluminum construction
- . Available in three lengths
- . Side opening for easy access
- . Designed for indoor/outdoor applications
- . IP 66 rated

3. INSTALLATION

1. Unlatch lid and open.
2. Loosen the screws (A) in the bottom of the enclosure and remove the camera sled from the rail.
3. Mount the camera to the sled with 1/4" - 20 UNC screw (B) that are provided in the parts bag.
4. Make the electrical terminations ensuring that they are electrically safe when connected to the terminal strip.
5. Close the lid and latch.

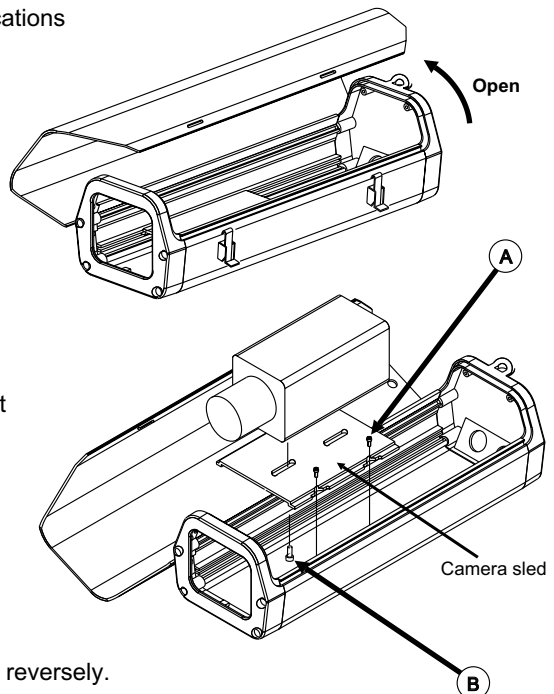

** The camera sled can be installed reversely.

4. SPECIFICATIONS

SMALL SIZE

MODEL A Enclosure environmental, 9.5-inch(24.13 cm) lower body length

MEDIUM SIZE

MODEL A Enclosure environmental, 12.5-inch(31.75 cm) lower body length
 MODEL B Same as MODEL A except has 120V thermostat controlled heater
 MODEL C Same as MODEL A except has 24V thermostat controlled heater
 MODEL D Same as MODEL A except has 230V thermostat controlled heater

LARGE SIZE

MODEL A Enclosure environmental, 15.7-inch(39.87 cm) lower body length
 MODEL B Same as MODEL A except has 120V thermostat controlled heater and blower
 MODEL C Same as MODEL A except has 24V thermostat controlled heater and blower
 MODEL D Same as MODEL A except has 230V thermostat controlled heater and blower

OPTIONAL ACCESSORIES

HEATER KIT A Heater kit, AC 80V ~ 230V, 20W
 HEATER KIT B Heater kit, AC 24V, 20W
 I/O PCB BOARD Control board with thermostat.
 One required when installing a heater, blower or in common

Note : Heater and Blower assemblies require I/O PCB BOARD assembly for connection.

GENERAL

Useful internal size accepts camera & lens combinations (including BNC connector) up to: of the small enclosure

SMALL A 8.5" L x 3.5" W x 2.5" H (21.59 cm x 8.89 cm x 6.35 cm)
 MEDIUM A 11.5" L x 3.5" W x 2.5" H (29.21 cm x 8.89 cm x 6.35 cm)
 MEDIUM B,C,D 9.5" L x 3.5" W x 2.5" H (24.13 cm x 8.89 cm x 6.35 cm)
 LARGE A 14.5" L x 3.5" W x 2.5" H (36.83 cm x 8.89 cm x 6.35 cm)
 LARGE B,C,D 11.0" L x 3.5" W x 2.5" H (29.21 cm x 8.89 cm x 6.35 cm)
 Window size .11-inch (3.0 mm) thick tempered glass 2.42" H x 2.65" W (6.15 cm x 6.75 cm)
 Construction Die-cast, extruded, and sheet aluminum
 Finish Light-gray polyester powder coat
 Camera mounting Removable camera sled with adjustable height
 Housing mounting Two(2) 1/4" -20 tapped holes
 Cable entry Two(2) .35-inch(9.0 mm) glands on rear of housing
 Security lock Located at rear of housing, available for security lock
 Environment Indoor/outdoor: -10°F to 120°F (-23.33°C to 48.89°C)
 Dimension See dimensional outline

WEIGHT

	Unit	Shipping
SMALL A	2.05 lb(0.93 kg)	2.31 lb(1.05 kg)
MEDIUM A	2.62 lb (1.19 kg)	2.95 lb (1.34 kg)
MEDIUM B,C,D	2.80 lb (1.27 kg)	3.13 lb (1.42 kg)
LARGE A	3.17 lb(1.44 kg)	3.68 lb(1.67 kg)
LARGE B,C,D	3.42 lb(1.55 kg)	3.92 lb(1.78 kg)

MODEL	A	B	C
SMALL SIZE	11.02 (28.00)	9.44 (24.00)	4.41 (11.20)
MEDIUM SIZE	14.17 (36.00)	12.59 (32.00)	7.40 (18.80)
LARGE SIZE	17.32 (44.00)	15.74 (40.00)	8.27 (21.00)

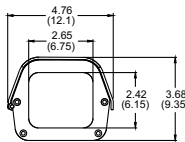

Unit: inch(cm)

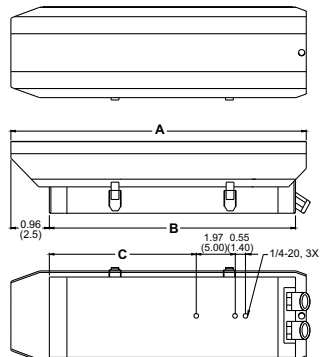

5. HEATER AND BLOWER KIT INSTALLATION

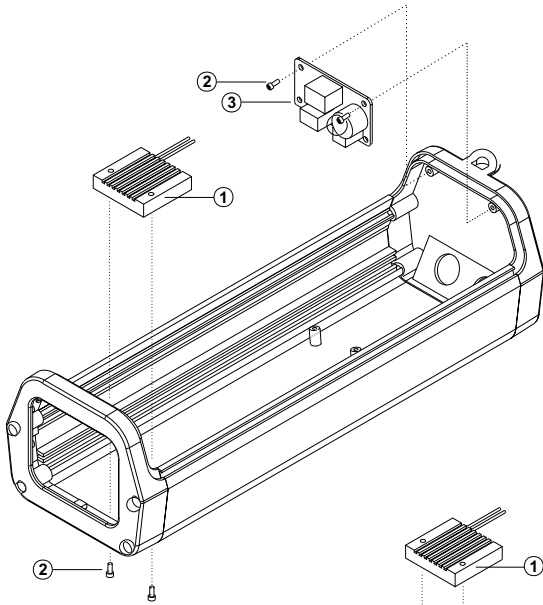

HEATER KIT INSTALLATION

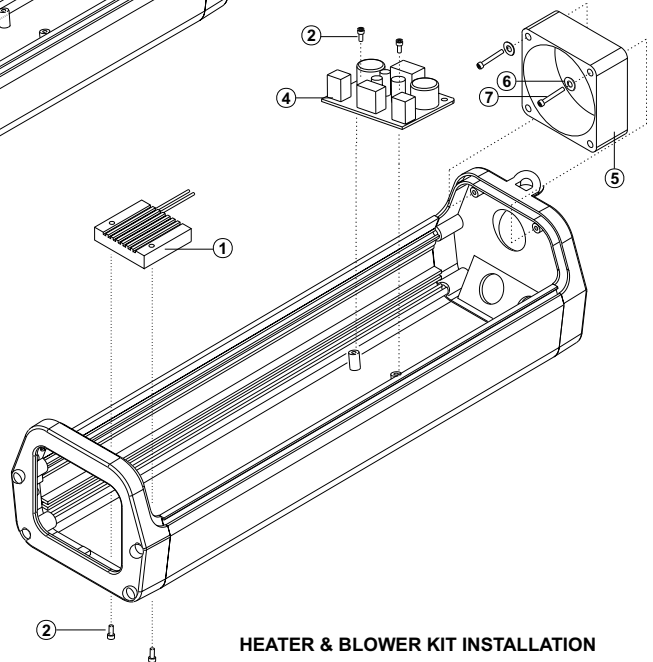

HEATER & BLOWER KIT INSTALLATION

ITEM	DESCRIPTION	Q'TY
1	Heater: AC110V~230V/ 20W Heater: AC24V/ 20W	1
2	Screw machine: Flat washer head NPC3x6	4
3	PCB & thermostat assembly (Heater only)	1
4	PCB & thermostat assembly (Heater and blower) AC24V (Heater and blower) AC110V ~ 230V	1
5	Fan: 24VDC (AC rectified), 19CFM	1
6	Flat washer M3	2
7	Screw machine: Pan head PC3x30 (24VDC Fan only)	2

6. WIRING DIAGRAM

* HEATER

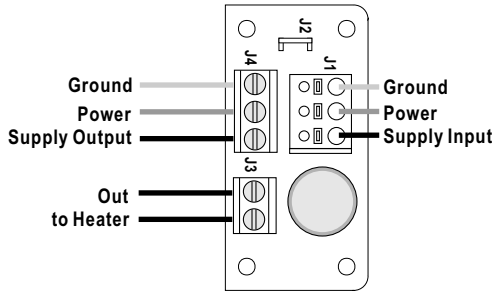

AC24V / AC120V / AC230V Heater PCB

* HEATER AND BLOWER

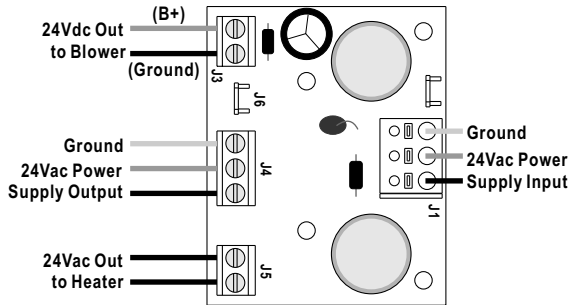

24 Vac

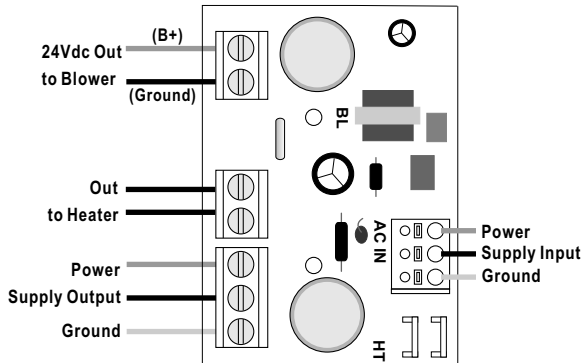

120/230 Vac

※ **POWER** : Use of Listed Class 2 power source.

7. SUNSHIELD INSTALLATION

Mount the sunshield from the top of the housing. Align the hole and secure using the small four philips panhead screws.

